



# Strasburg Heritage Advertiser's guide



# Why advertise in **Strasburg Heritage** magazine?

- ▶ Advertisements in **Strasburg Heritage** magazine are like targeted direct-mail advertisements. But your customers are likely to spend time looking at the magazine. They are also likely to keep the magazine on hand, unlike direct-mail postcards, which are often discarded quickly.
- ▶ The magazine reaches your customers in Strasburg Borough and Strasburg Township. Many residents own their homes, and there are many historic properties. Information about the magazine distribution and demographics (provided by USPS *Every Door Direct Mail*®) is shown on the following page...

magazine email:  
strasburgheritagemag@gmail.com

The logo for the Strasburg Heritage Society features a large, stylized, cursive letter 'S' on the left. To the right of the 'S', the words 'STRASBURG' and 'HERITAGE SOCIETY' are stacked in a serif font.



# Magazine distribution area & demographics

Age distribution for Strasburg Borough & Township Distribution area (blue highlight): 2465 residences; also available online for free.

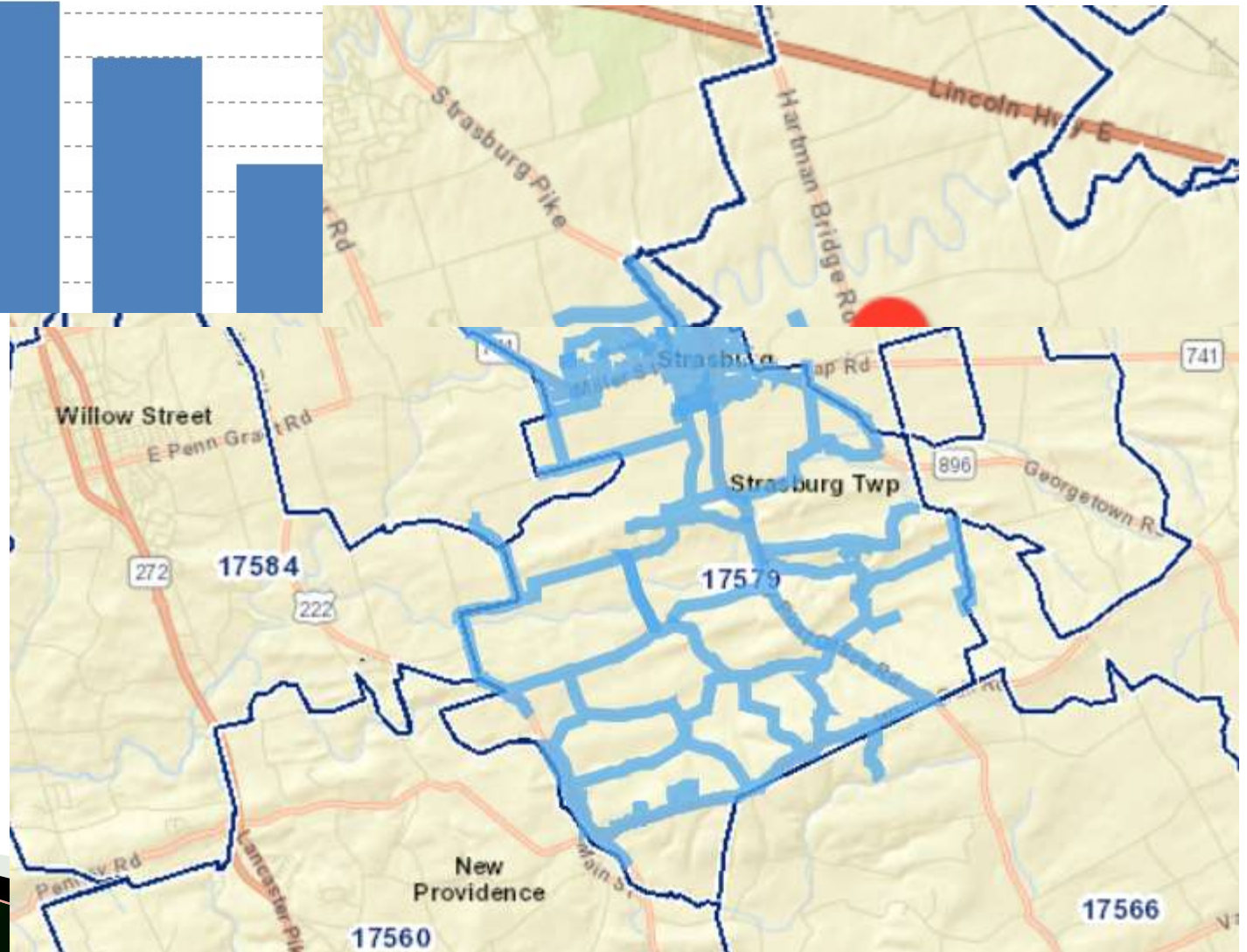
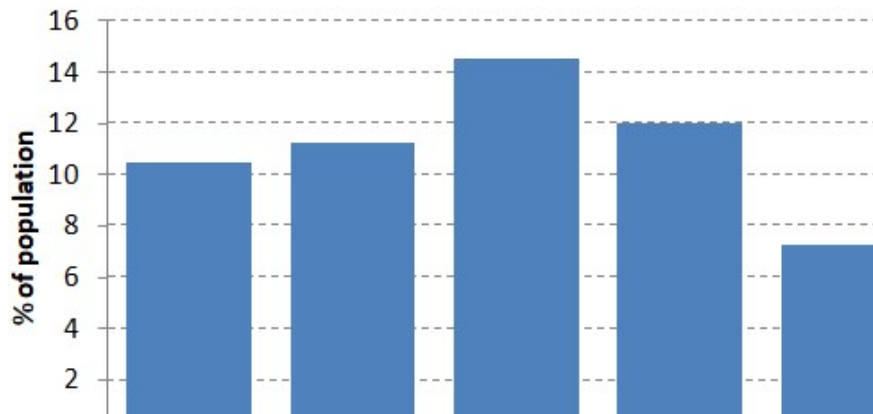

# Why advertise in **Strasburg Heritage** magazine?

- ▶ The cost to reach your customers is as low as 2.6¢ per household! (for a 1 / 8<sup>th</sup> page “business card” ad). See the included price lists at the end of this document.
- ▶ The low cost and targeted placement can produce real sales increases. Here are two simple example calculations, to give some idea of the potential sales impact:

**Suppose the average customer in your store spends \$20.**

Let's assume that 1% of the magazine readers become new customers (one in 100).

With 2500 magazines in circulation, that means the ad generated  $0.01 \times 2500 = 25$  new customers.

On average, each new customer spends \$20, so that's  $\$20 \times 25 = \$500$  total in new sales.

**Suppose you sell a product or service that costs \$500.**

Let's assume that 1% of the readers (one in 100) will call to inquire, and you're able to sell your service to 33% of these (1 in 3).

With 2500 magazines in circulation, that means the ad generated  $0.01 \times 0.33 \times 2500 = 8.25$  new customers. Therefore, your ad in the magazine has generated  $8.25 \times \$500 = \$4125$  in new sales.

magazine email:  
[strasburgheritagemag@gmail.com](mailto:strasburgheritagemag@gmail.com)

 STRASBURG  
HERITAGE SOCIETY





# Why advertise in **Strasburg Heritage** magazine?

- ▶ Your ad will look its best! All ads are published in **FULL COLOR!** Your ad can include full color high-resolution photographs!
- ▶ The magazine with your advertisement is posted online on the Strasburg Heritage Society website where it will continue to be seen by customers.
- ▶ Your advertisement shows that you support the local community and promotes good will toward your business.

magazine email:  
strasburgheritagemag@gmail.com



# How to place an ad in **Strasburg Heritage** magazine

- ▶ To place an ad, contact us at:  
[strasburgheritagemag@gmail.com](mailto:strasburgheritagemag@gmail.com)
- ▶ We will accept new advertisements at any time up to the advertising cut-off date.
- ▶ Special ad location requests (covers, etc.) will be honored on a first come, first served basis.
- ▶ Space for an ad is guaranteed once payment is received.
- ▶ For the spring/summer issue, payment and artwork for ads must be received no later than February 28.
- ▶ For the fall/winter issue, payment and artwork for ads must be received no later than August 31.
- ▶ Advertising space does sell out. Be sure to purchase your ad early!

magazine email:  
[strasburgheritagemag@gmail.com](mailto:strasburgheritagemag@gmail.com)

*SH* STRASBURG  
HERITAGE SOCIETY



# Requirements for ad artwork

1. Digital image files are preferred for ad artwork. Note the following:
  - For acceptable reproduction of the artwork, *image resolution must be at least 300 dots/inch (pixels/inch)*.
  - The following file formats can be accepted: .jpg, .png, .tiff, .gif, .psd, .ppt, .pub, doc.
2. We will scan printed artwork, but enlarging the image is not recommended, as the quality of the final image will suffer.
3. The following pages show the maximum dimensions for each size ad, along with the minimum image sizes in pixels.
4. The proportions of ad artwork can't be changed. For example, artwork for a business card can't be "stretched" to fill a quarter-page ad.
5. Ads with "clip out" coupons will not be accepted.

magazine email:  
strasburgheritagemag@gmail.com

 STRASBURG  
HERITAGE SOCIETY



# Strasburg Heritage magazine ad pricing

full page – \$600

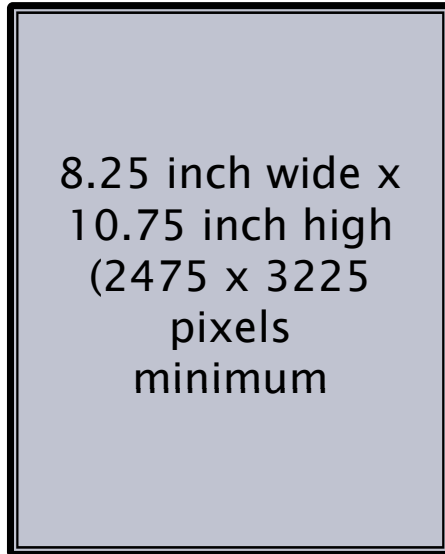

Same price for any page, even inside front or inside back covers! (No full page ad on outside back cover due to required postal markings).

half page – \$300

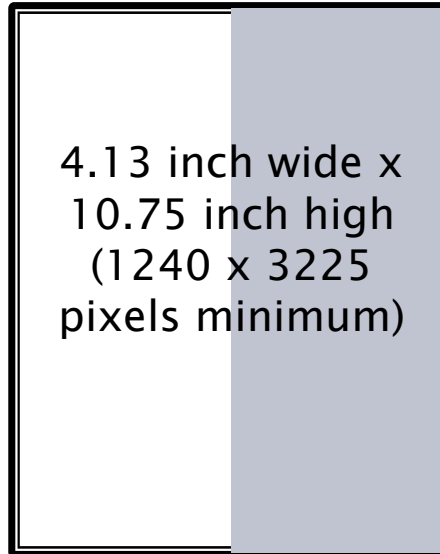

vertical format  
left or right side

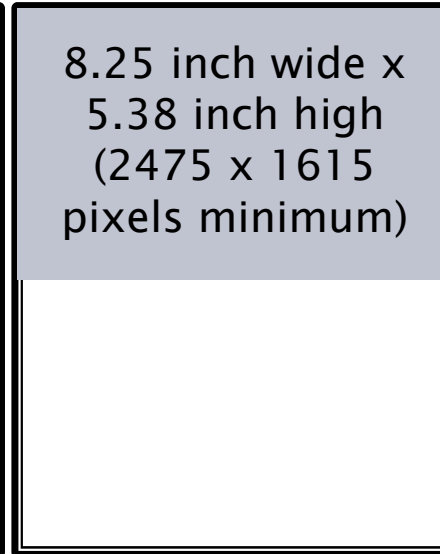

horizontal format  
top or bottom

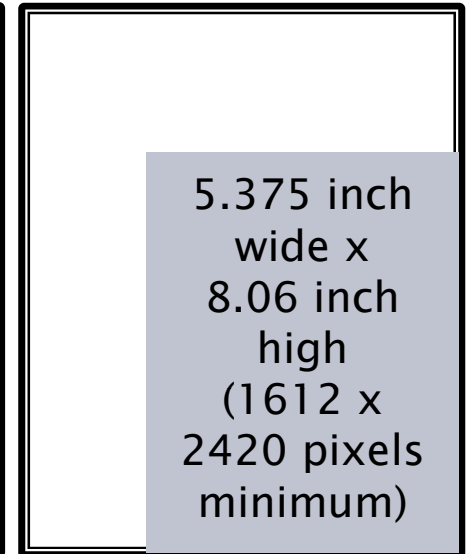

$\frac{2}{3}$  wide x  $\frac{3}{4}$  high

magazine email:  
strasburgheritagemag@gmail.com

STRASBURG  
HERITAGE SOCIETY





# Strasburg Heritage magazine ad pricing

1/3 page – \$200

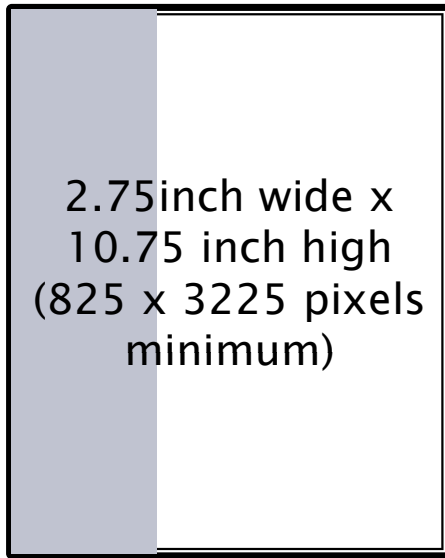

vertical format  
left or right side

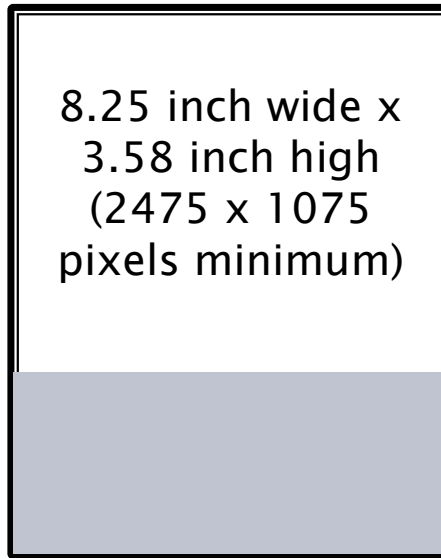

banner format  
top or bottom  
(middle if paired with  
another banner ad)

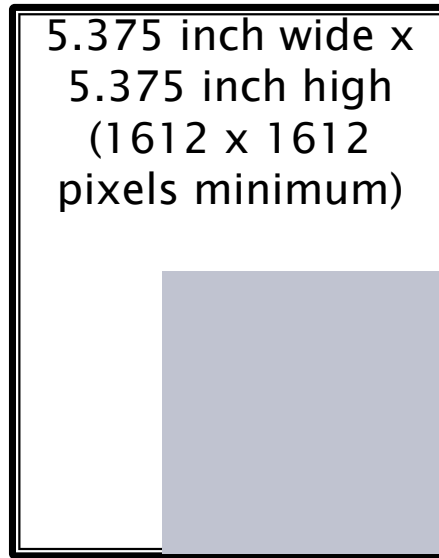

square format  
( $\frac{2}{3}$  wide x  $\frac{1}{2}$  high)

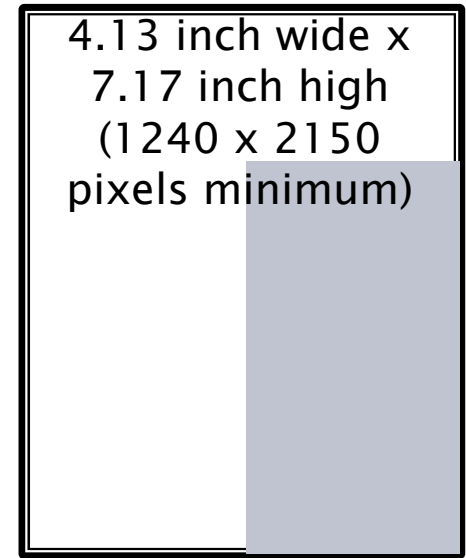

$\frac{1}{2}$  wide,  $\frac{2}{3}$  high

magazine email:  
[strasburgheritagemag@gmail.com](mailto:strasburgheritagemag@gmail.com)

*SH* STRASBURG  
HERITAGE SOCIETY



# Strasburg Heritage magazine ad pricing

1/8 page – \$75

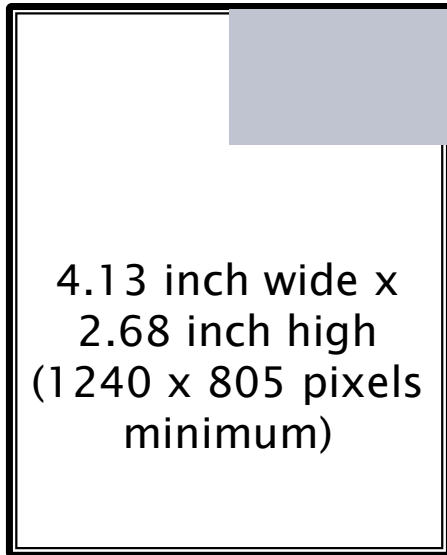

“business card”  
format

quarter page – \$150

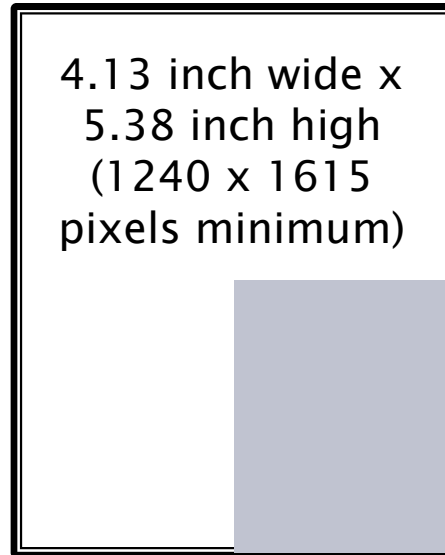

quadrant format

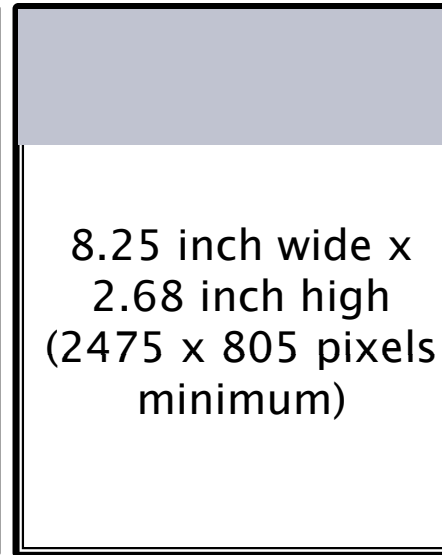

banner format  
top or bottom  
(middle if paired with  
another banner ad)

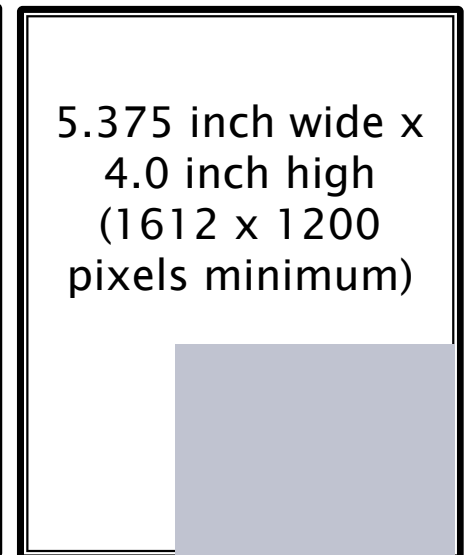

$\frac{2}{3}$  wide x  $\frac{3}{8}$  high

magazine email:  
strasburgheritagemag@gmail.com

